

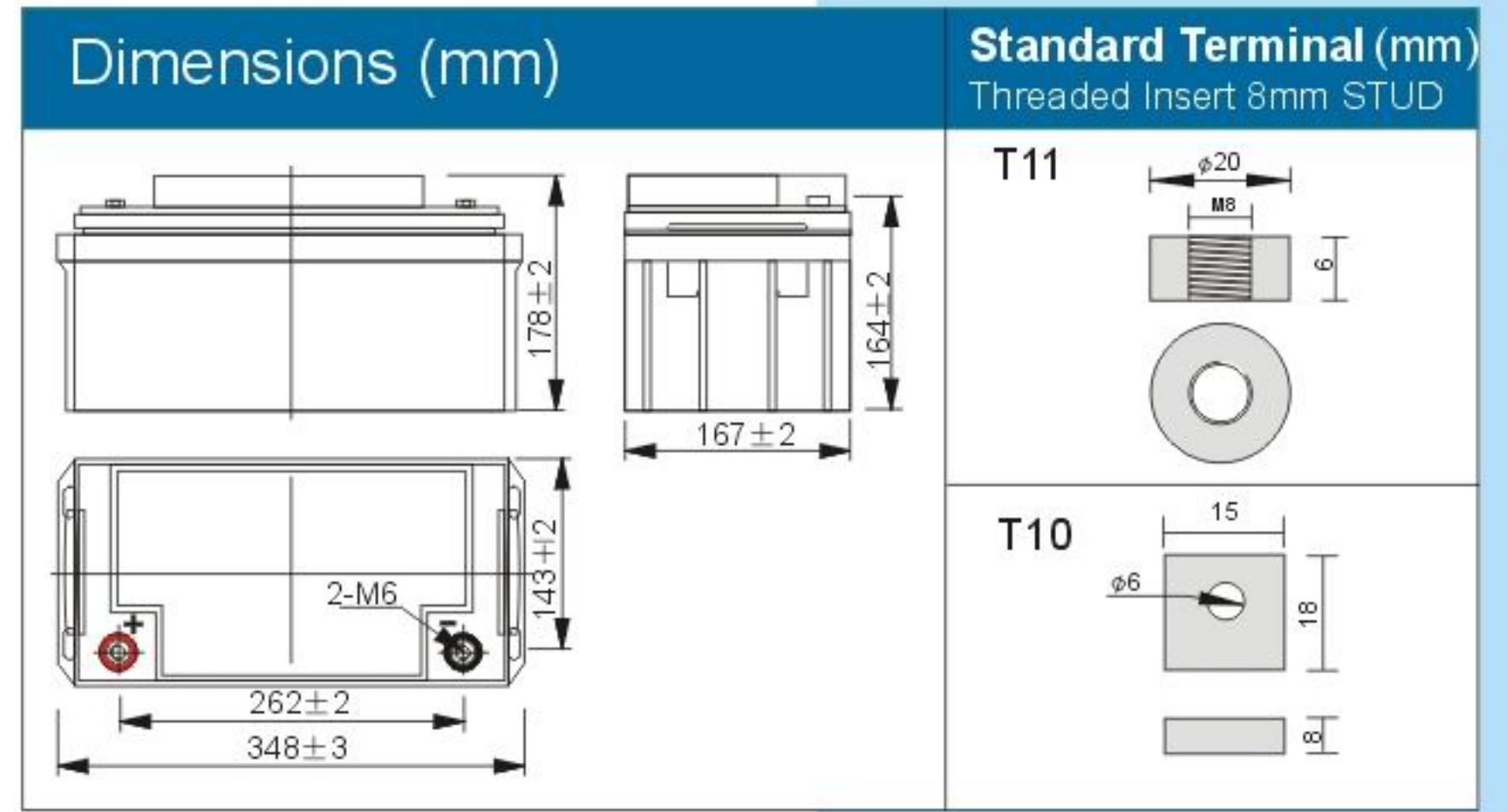

DJM1265(12V65AH)

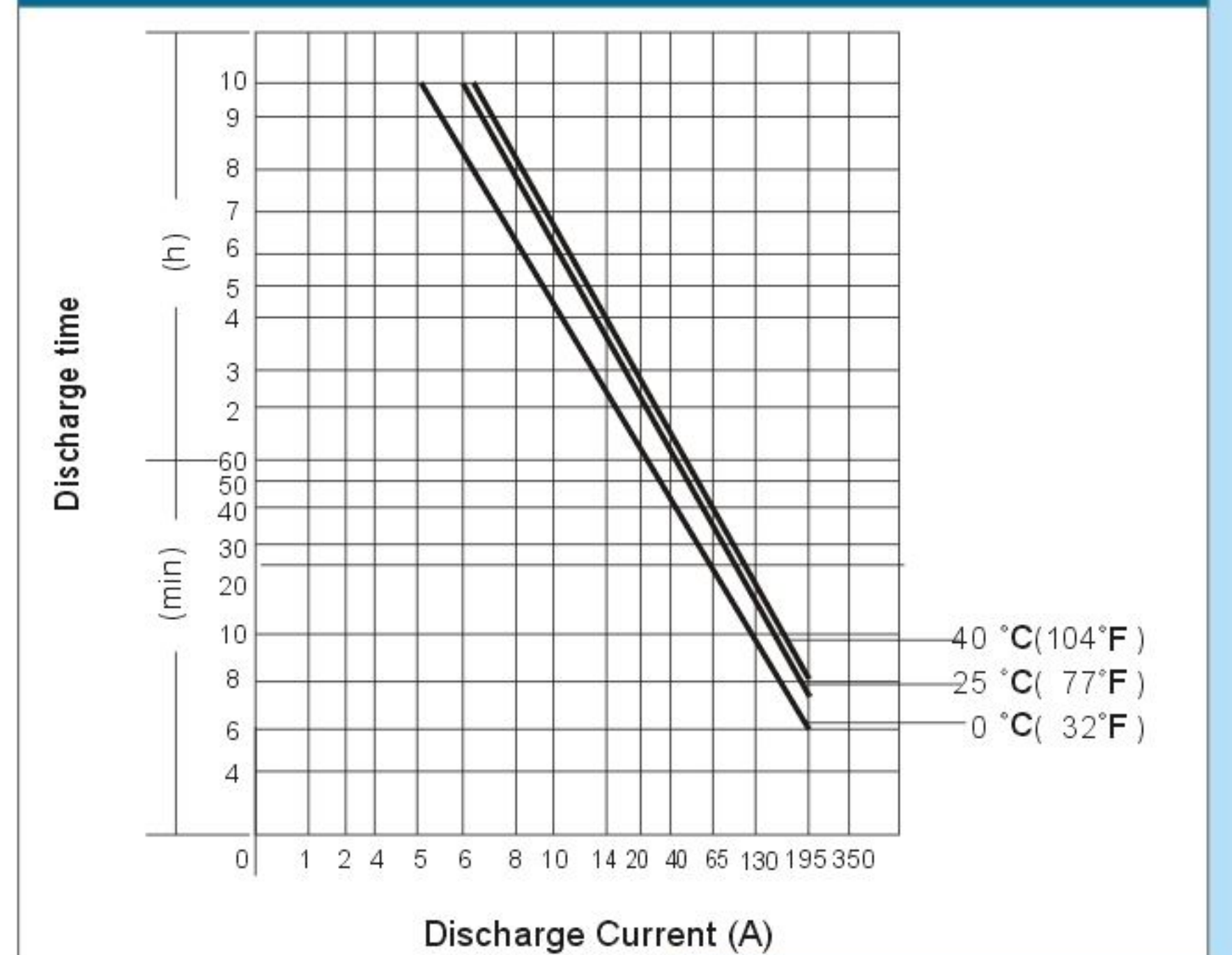

Discharging Current & Discharge Duration Time



Physical Specification		
Nominal Voltage	12V	
Nominal Capacity (10HR)	65AH	
Dimension	Length	348±3mm (13.70 inches)
	Width	167±2mm (6.57 inches)
	Container Height	178±2mm (7.01 inches)
	Total Height (with Cover)	178±2mm (7.01 inches)
Weight	Approx 21 kg (46.3 lbs)	
Standard Terminal	Threaded Insert 8mm STUD	

Discharge Characteristics (25°C, 77°F)

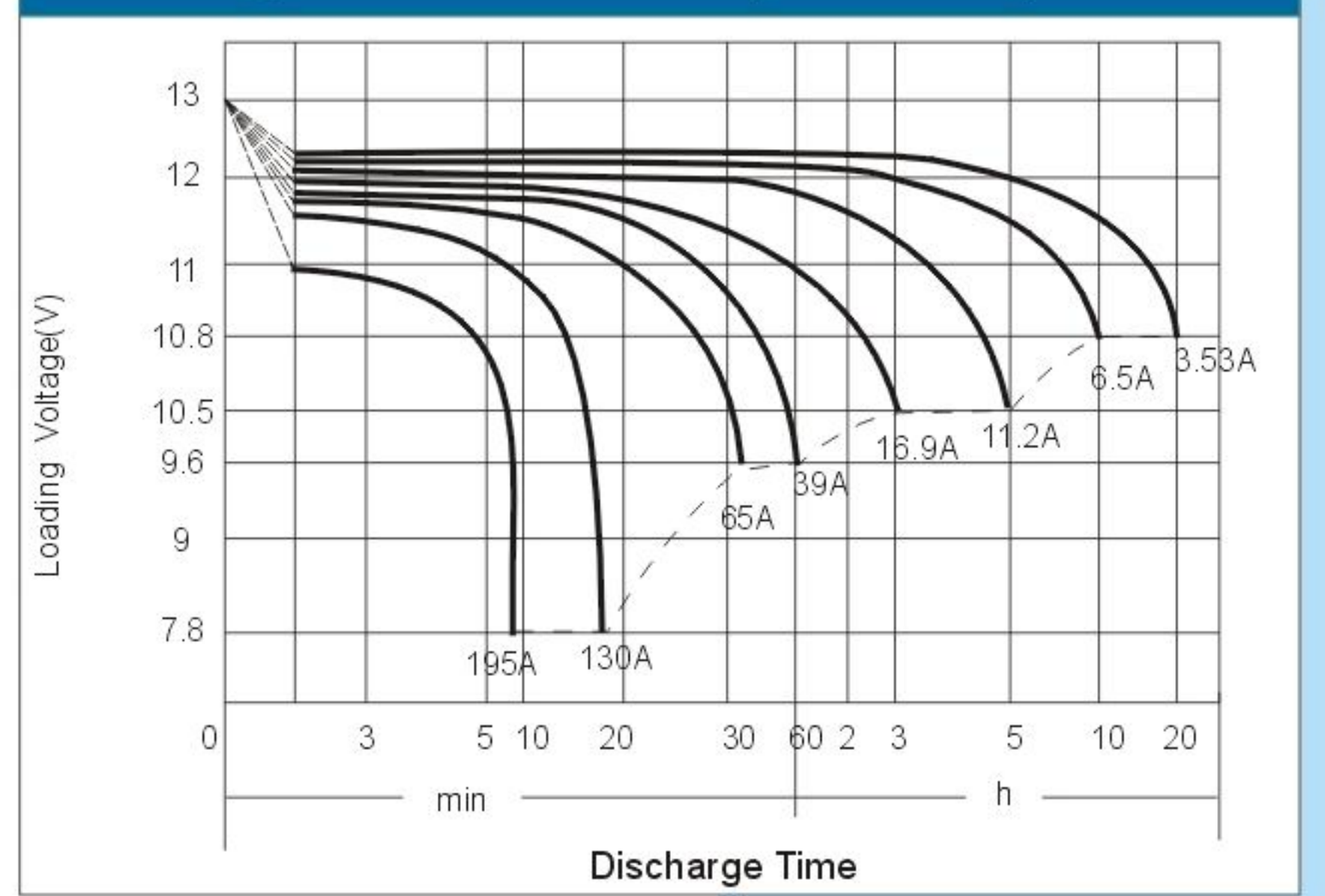

Electrical Specification					
Rated Capacity	20 hour rate (3.53 A)	70.6AH	Constant Voltage	Cycle	Initial Charging Current less than 19.5A. Voltage 14.4V~ 15.0V at 25°C (77°F) Temp. Coefficient -30mV/°C
	10 hour rate (6.5 A)	65.0AH			
	5 hour rate (11.2 A)	56.0AH			
	3 hour rate (16.9A)	50.7AH			
Capacity affected by Temperature	40°C (104°F)	103%	Charge	Standby	No limit on Initial Charging Current Voltage 13.5V~13.8V at 25°C(77°F) Temp. Coefficient - 20mV/°C
	25°C (77°F)	100%			
	0°C (32°F)	86%			

Constant Current (Amp) and Constant Power (Watt) Discharge Table (25°C, 77°F)

Amp/Watt/Cell	Time(minute)	10	15	20	30	45	60	120	180	240	300	360	480	600	1200
	Final voltage	1.3	1.3	1.3	1.6	1.6	1.67	1.7	1.75	1.75	1.75	1.75	1.8	1.8	1.8
A		162.5	123.5	97.5	74.8	52.0	39.0	22.8	16.9	13.0	11.2	9.9	7.7	6.5	3.53
W		305.5	234.0	191.1	141.1	103.4	77.2	45.2	33.7	25.9	22.3	19.8	15.5	13.0	7.00